

SinkFix®

Superior Wash Basin Fixing Plate
The Modern Choice for Professional Installers

For use with Wall Hung Wash Basins
and Semi and full Pedestals

Contents of SinkFix Box (Code PT314000):
1 x Wash Basin Fixing Plate
2 x Nylon Bushings, 2 x M10 Flange Nuts,
2 x 55mm long M10 Bolts
(Optional 120mm length available separately, Code PT314001)
Please Note: Fixing Screws and Wall Plugs NOT Included

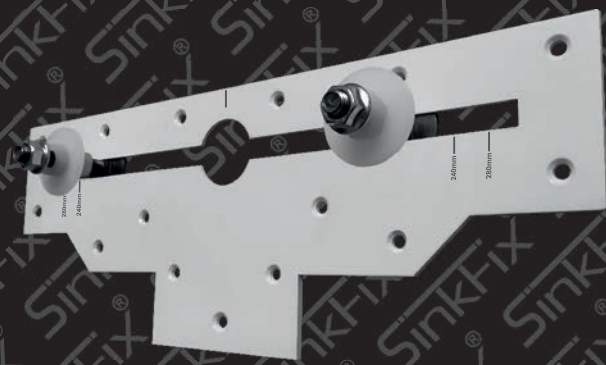

www.sinkfix.co.uk

Code: PT314000
SinkFix® is a Registered Trademark
of PlatinumPie Ltd
Patent Pending



Fixing Instructions

Recommended Tools for installation:

Power Drill, 6mm masonry drill bit, Pencil,
Phillips head driver bit, Spirit Level,
15mm Spanner, Tape Measure.

Important Notes:

- Before drilling, always check to make sure there are no services in the area.
- When installing on a plasterboard/stud wall, make sure there is a proper fixing/stud to attach to behind.
- Make sure you drill the holes accurately to ensure the countersunk screws will sit flush with the surface of the plate.
- Do not over-tighten the flange nuts.

Preliminary Steps

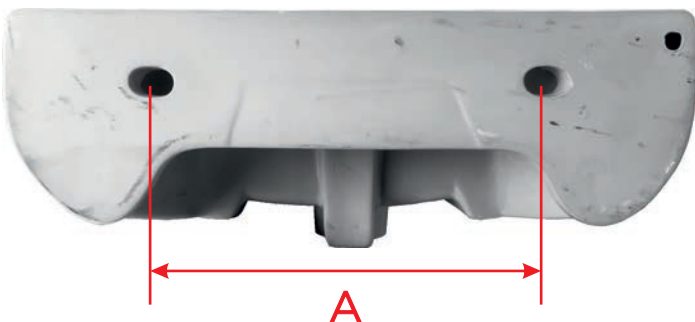

Take the nylon bushes out of the bag and place them inside the wash basin, do this to ascertain the best position for them. Sometimes due to the moulding of the basin the central point isn't always the best suited point, the bushes may sit better nearer together, whatever works out the best suited position for the basin (measurement **A**), will be the final position of the M10 x 55mm bolts.

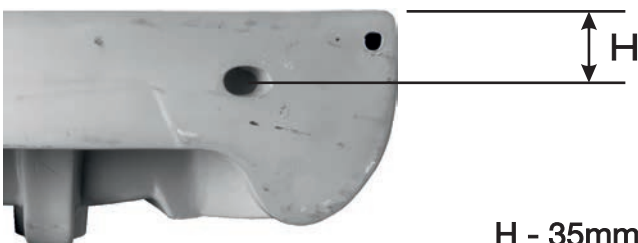

$$H - 35\text{mm} = B$$

B = The distance between red & green lines

1. Draw a horizontal line representing the finished height of the basin (shown in **RED**) (This may be dependant if using a full pedestal and/or where the services are. Draw another horizontal line (shown in **GREEN**) under the red line at the distance obtained (Measurement **B**) in the preliminary steps. This represents the top of the SinkFix® plate.

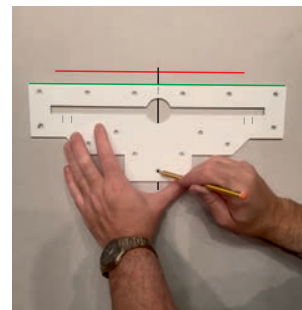
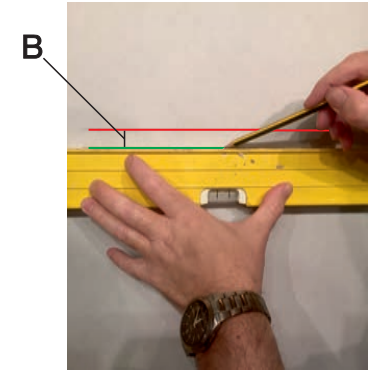
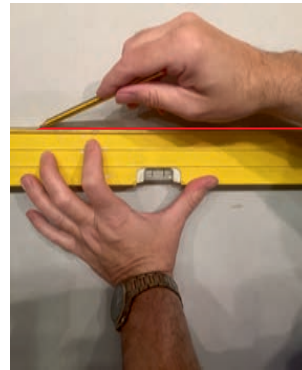

2. Draw a vertical line perpendicular to the horizontal lines which corresponds to the centre of the basin, align the plate then mark the relevant holes you will be using to secure the plate.

3. Drill and plug using suitable wall fixings. We recommend using at least 7 fixing points. For a plasterboard wall; If installing a wall hung basin with or without a semi pedestal make sure you locate a stud behind. In the event of installing a wash basin with a full pedestal, fixing to a plasterboard wall without a stud is sufficient with strong appropriate fixings. For a 'Dot and Dab' wall use appropriate fixings such as Corefix™. (www.corefixed.com) Fix loosely at this point, insert the M10 55mm bolts and slide to their relevant positions (**A**) as obtained in the preliminary steps. Finally tighten all screws.



Important:
Make sure the countersunk screws sit flush with the surface of the plate. If in any doubt on load bearing, contact a professional installer.



4. Once the plate is in position tile around and up to the edge. The plate can be installed on a pre-tiled surface. The Wash basin will stand proud of the wall by 3.8mm but this can be silenced.



5. Put silicone on the back of the wash basin where it meets the tiles, this will help reduce noise vibration. Offer up the wash basin to the protruding bolts and insert the nylon bushings through the wash basin holes (shown opposite), screw on the flange nuts and tighten using a 15mm spanner. Do not over-tighten.

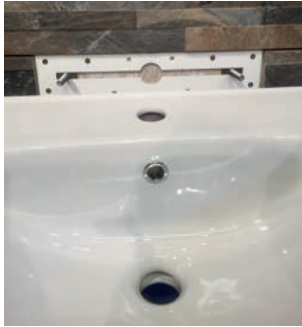

Tip: The nylon bushings are such that they will alter the height of the wash basin so that the horizontal level can be achieved /fine tuned. Setting 0-3 will gradually increase the height.



Setting 0-3 will gradually increase the height.

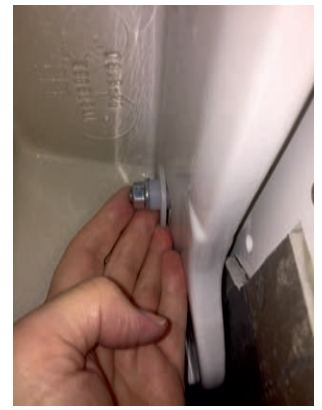

When changing the basin in the future. Just remove the old basin, loosen the screws, adjust the bolts to the corresponding distance of the new basin, re-tighten and re-fit.

The bolts supplied as standard are M10 x 55mm, however extra long M10 x 120mm bolts are available at:

www.sinkfix.co.uk



SinkFix®

Superior Wash Basin Fixing Plate
The Modern Choice for Professional Installers

www.sinkfix.co.uk

Code: PT314000
SinkFix® is a Registered Trademark
of Platinumpie Ltd
Patent Pending



@tubfix

SinkFix v1

